

Open Hardware & Arduino

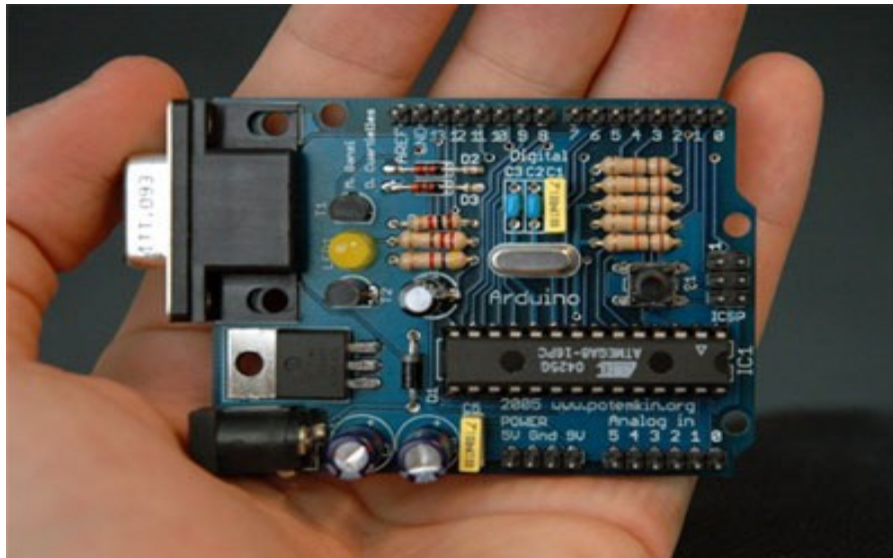

Jeronimo Avelar Filho

jeronimo@blogdoje.com.br
www.blogdoje.com.br

Open Hardware

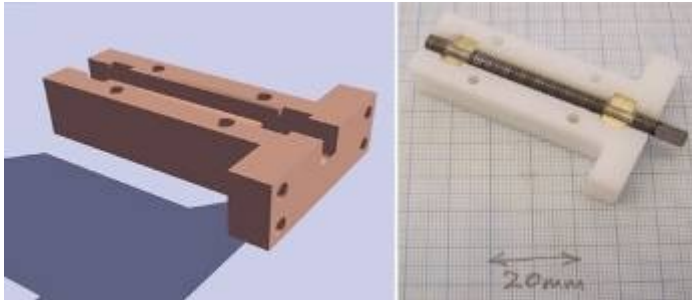

Mini Amplifier with LM386

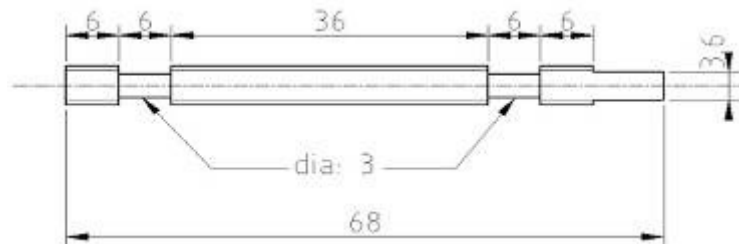
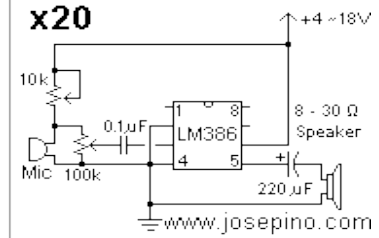
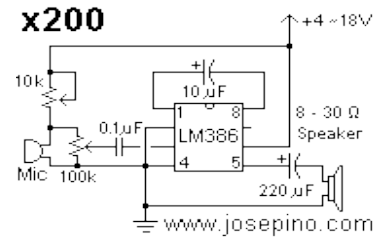



Open Hardware

- Eletronica SABER
- Nova Eletrônica
- Circuit Cellar Magazine
- Mechatronica Facil
- Elektor



O que é o Open Hardware Arduino ?

- Plataforma de Computação Física Open Source
- Livre para inspecionar e modificar
- Plataforma física + Software
- Funcionamento independente
- Conexão a outros dispositivos



Computação Física ?

- “Interaction Design - Design of any interactive experience”.
- Interaction Design >>> Physical Interaction Design >> Physical Computing
- Projeto de objetos interativos que podem comunicar-se com seres humanos usando sensores e atuadores controlados por um comportamento implementado em software em execução dentro de um microcontrolador.
- Ambiente inteligente , “everyware”, objetos inteligentes, roupa inteligente
- Arduino - Massimo Banzi , David Cuartielles e outros professores em Ivrea

O que é o Open Hardware Arduino ?

- IDE : AVR-GCC, avr-libc , AVRlib , Java , Processing
- Similar ao Basic Stamp (PIC) so que + barato, + rapido e aberto
- Microcontrolador AVR ATmega8

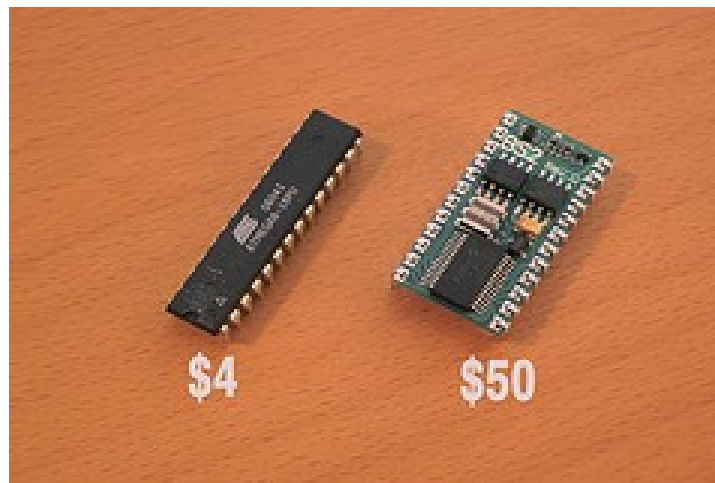



O que é o Open Hardware Arduino ?

- Arduino possui um “bootloader”
 - Bootloader = “carregador” de outros programas através da porta serial
 - Ativo durante 5 segundo após o reset



O que é o Open Hardware Arduino ?

- 8 kbytes de memória flash para memória de programa
- 1Kbyte de RAM
- 16 MHz de clock.
 - Primeiro IBM PC : 4.77 Mhz
- Entradas e Sairas
 - 13 pinos de I/O digital
 - 5 pinos de entrada analógica

O que é o Open Hardware Arduino ?

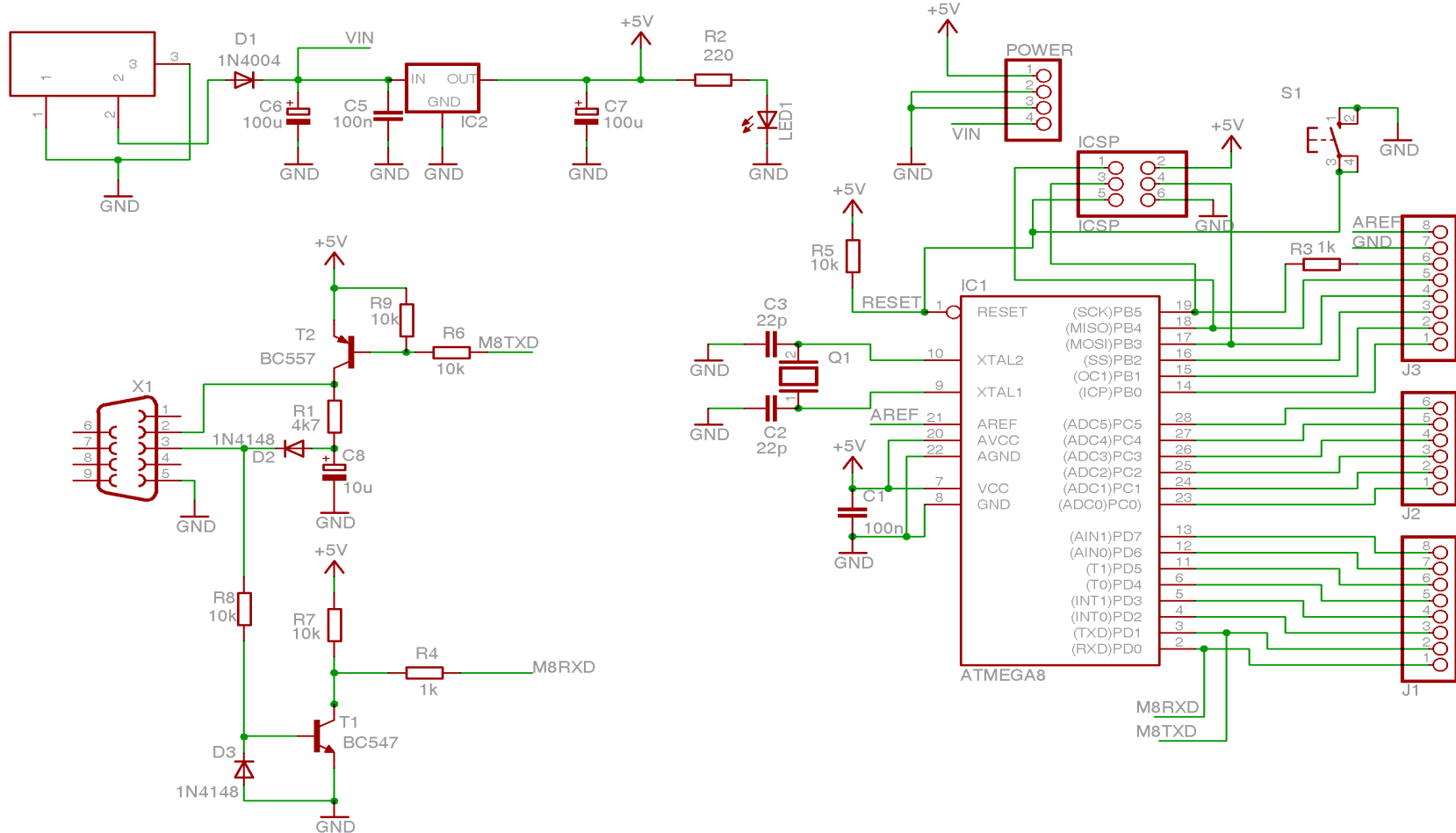



O que é o Open Hardware Arduino ?

- Como programa-lo
 - Escreva os programas no PC
 - Download para a placa Arduino
 - Comece a usar o Arduino !!!

Placa Arduino Industrializada

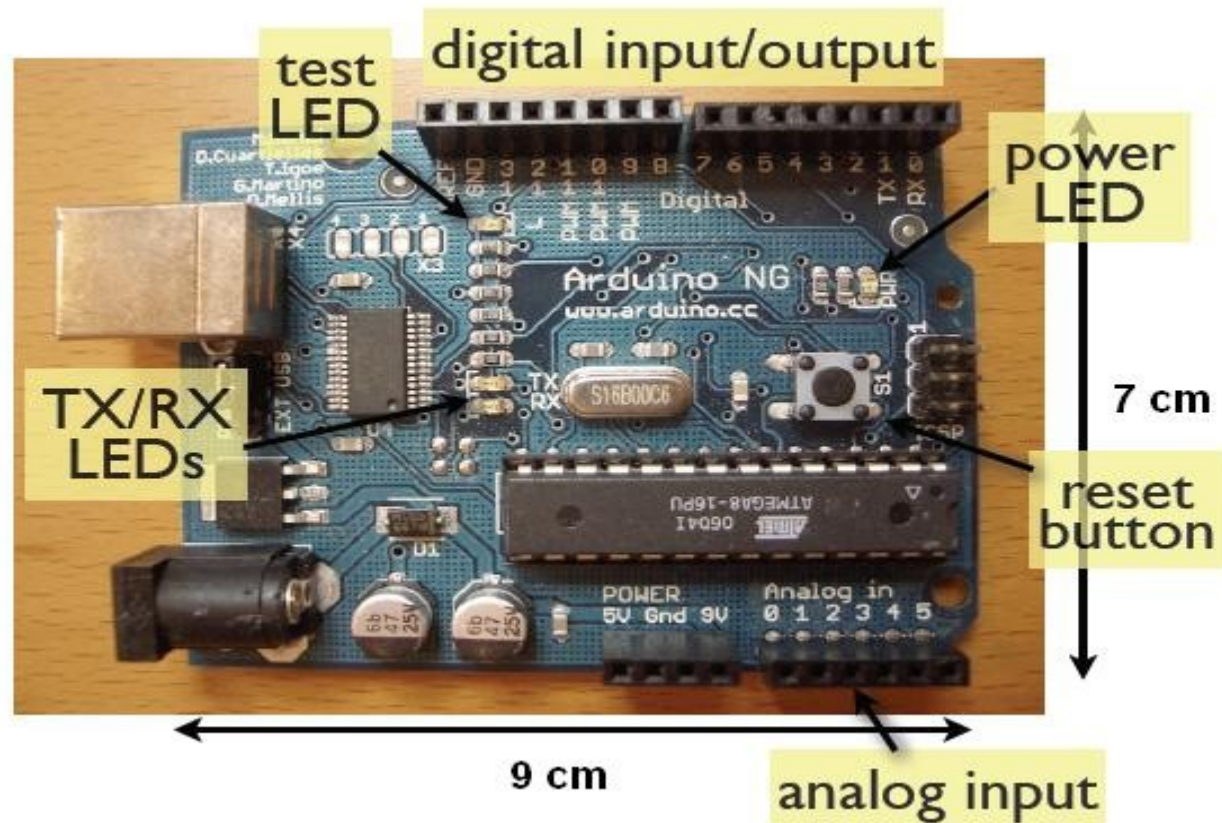

Placa Arduino Artesanal

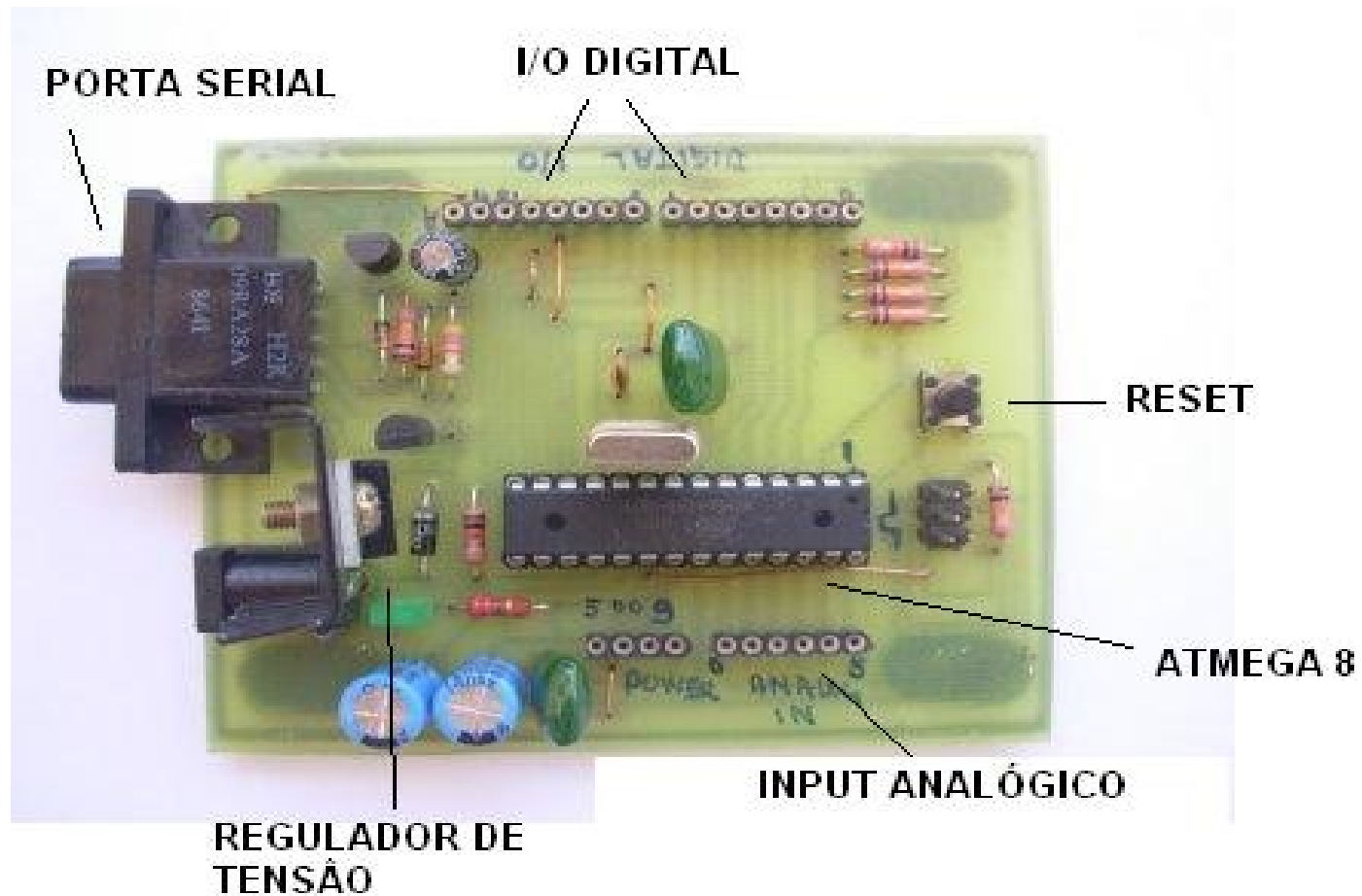

Arduino Severino

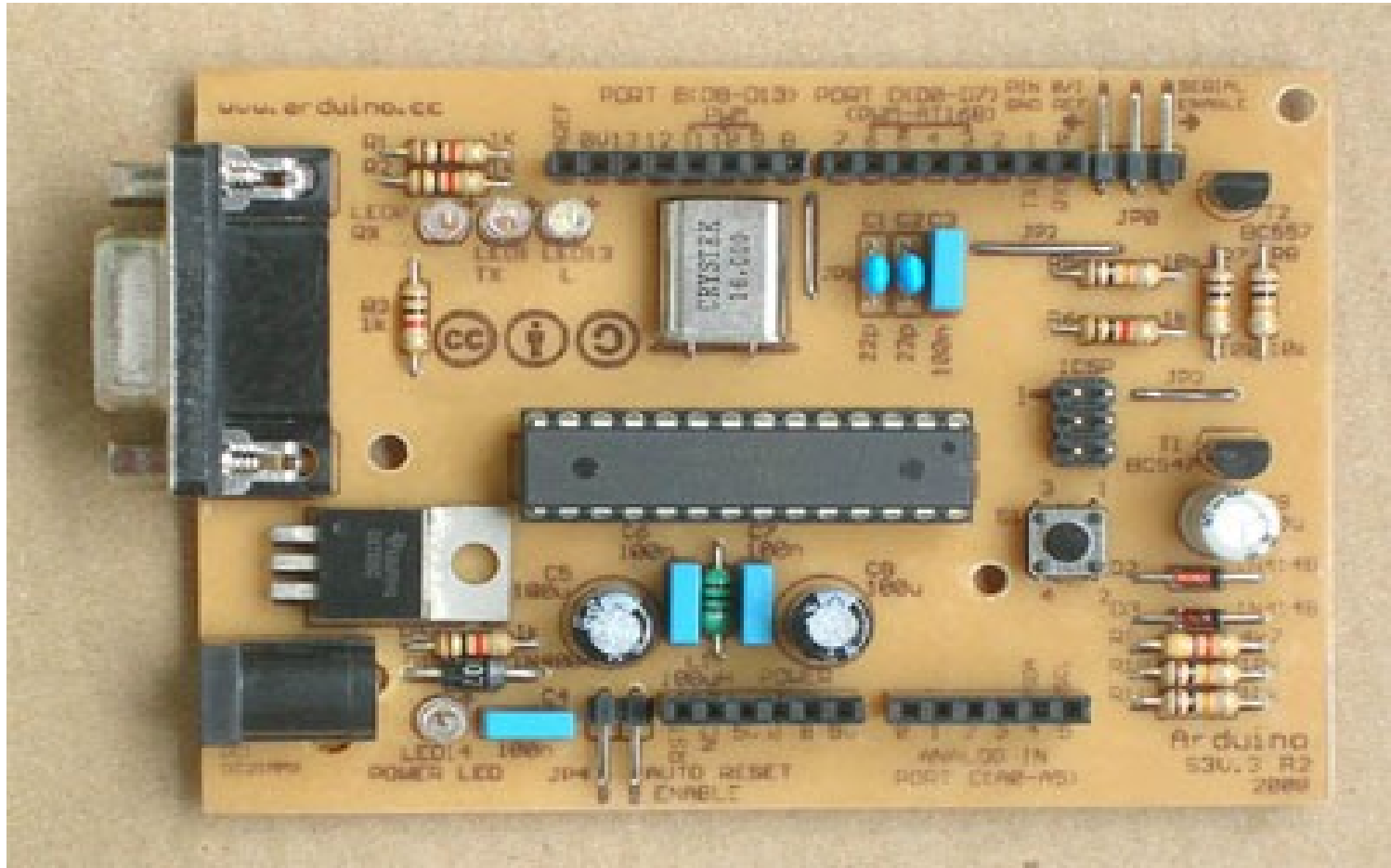

Expansões - Shields



IDE Arduino – Hello World

Compilar

```
Arduino - 0008 Alpha
File Edit Sketch Tools Help

led_blink2

*
* based on an original by H. Barragan for the Wiring i/o board
*/

int ledPin = 13;           // LED conectado ao pino digital 13

void setup()
{
  pinMode(ledPin, OUTPUT); // configura o pino digital pin como saída
}

void loop()
{
  digitalWrite(ledPin, HIGH); // Liga o LED
  delay(500);                 // espera 500 ms
  digitalWrite(ledPin, LOW);  // Desliga o LED
  delay(500);                 // espera 500 ms
}

1
```

Gravar no Arduino

Área de Edição

Status



Linguagem de Programação

- Digital I/O
 - `pinMode(pino, modo)`
 - `digitalWrite(pino, valor)`
 - `int digitalRead(pino)`
- Analog I/O
 - `int analogRead(pino)`
 - `analogWrite(pino, valor) - PWM`
- Comunicação Serial
 - `Serial.begin(velocidade)`
 - `int Serial.available()`
 - `int Serial.read()`
 - `Serial.flush()`
 - `Serial.print(dados)`
 - `Serial.println(dados)`
- Estruturas de Controle
 - `if`
 - `if...else`
 - `for`
 - `switch case`
 - `while`
- Operadores
 - `+` (adição)
 - `-` (subtração)
 - `*` (multiplicação)
 - `/` (divisão)
 - `%` (modulo)
 - `&&` (and)
 - `||` (or)
 - `!` (not)
- Etc...



Linguagem de Programação

```
void setup()  
{  
    statements;  
}
```

```
void loop()  
{  
    statements;  
}
```



Usando o Arduino

- Escrever o programa – Diversos exemplos na IDE
- Compilar , tirar erros
- Reset
- Carregar na placa

Ciclo de Vida Arduino

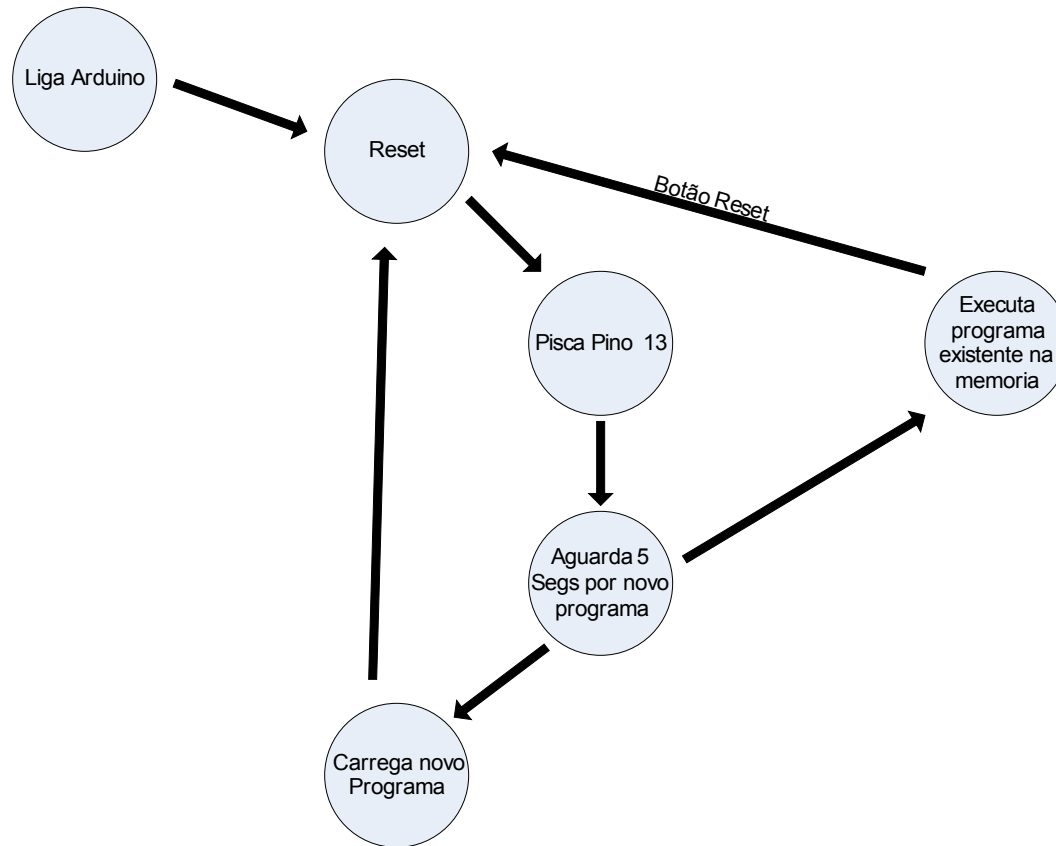

Hello World Arduino

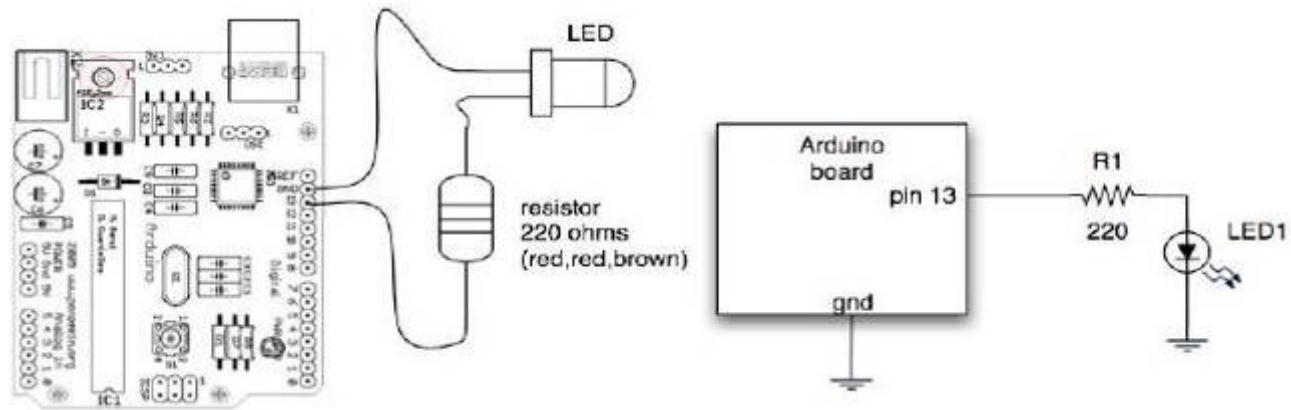

```
int ledPin = 13; // LED conectado ao pino digital 13

void setup()
{
  pinMode(ledPin, OUTPUT); // configura o pino digital pin como saída
}

void loop()
{
  digitalWrite(ledPin, HIGH); // Liga o LED
  delay(500); // espera 500 ms
  digitalWrite(ledPin, LOW); // Desliga o LED
  delay(500); // espera 500 ms
}
```



Como obter o Software

- Download em www.arduino.cc
 - Versões para
 - Linux
 - Windows
 - Mac (PPC e Intel)

Como obter o Hardware

- Comprar pronto: \$35,00 a \$150,00 dolares

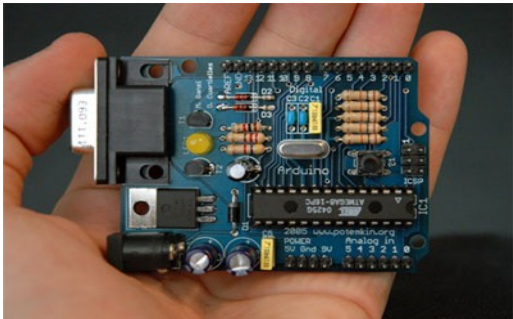

Serial

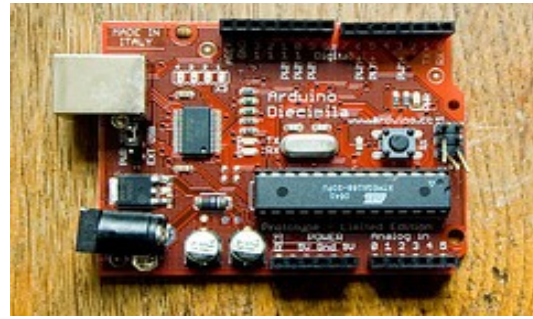

USB



Bluetooth

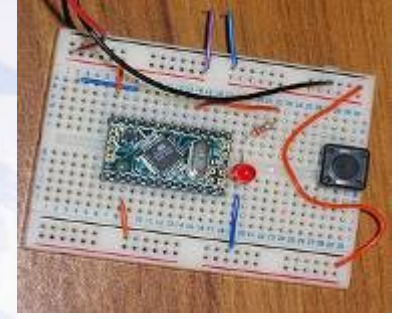

Mini

www.pcb-europe.com

www.sparkfun.com

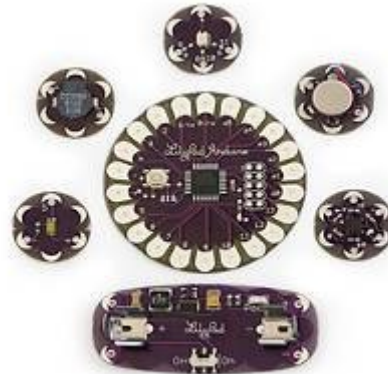

LilyPad

Como obter o Hardware

- Tatuino – www.tato.ind.br



● ● ● | Como obter o Hardware

- Construir o seu , você mesmo !!!:
 - Workshops de construção



Como obter o Hardware

- Baixar layout da placa
- Transferir para circuito impresso
- Corroer
- Montar
- Soldar
- Testar

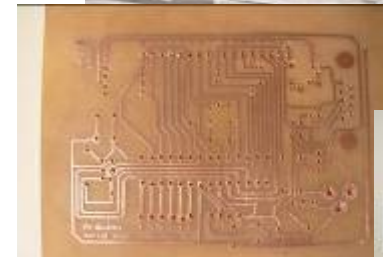
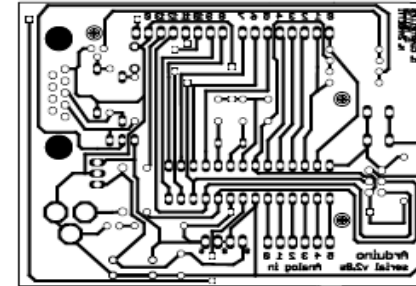



Como obter o Hardware

- Custo: R\$ 30,00
 - Transistores , capacitores , resistores , regulador, circuito impresso
 - COMETA, CONECTA - 310/110 SUL
 - ATMEGA8 ou 168
 - Distribuidores ATMEL
 - Mercado Livre



Usos do Arduino

- Educação
- Robótica
- Controle de Ambiente
- Objetos Inteligentes
- Exposições e Eventos
- Iluminação
- Wearable Computing

Usos do Arduino



Interações Virtuais

**Arduino
+ GPS**

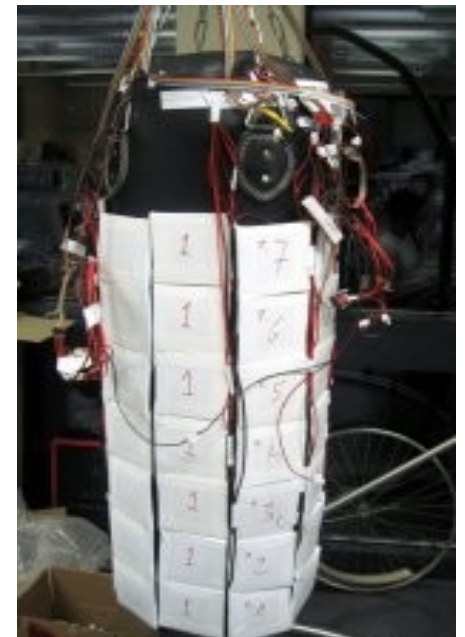

Usos do Arduino

- Wearable Computing

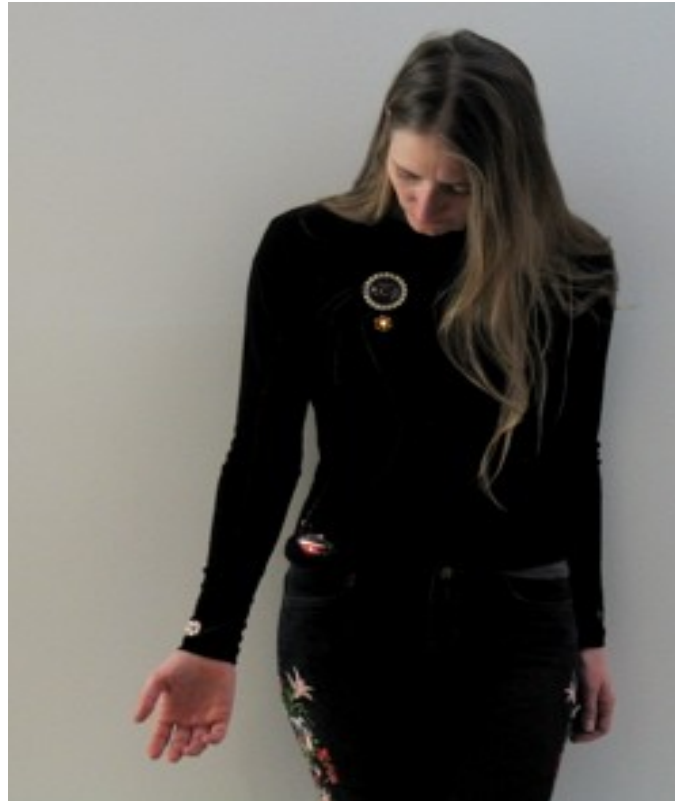

Usos do Arduino

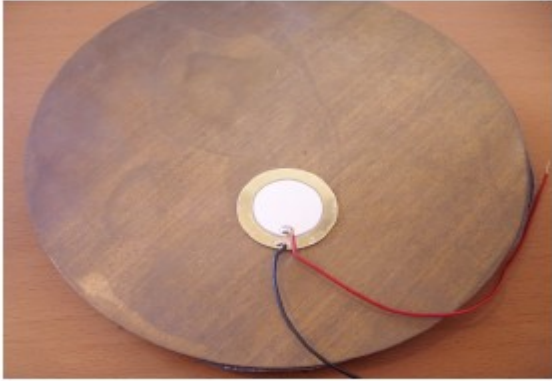

Instrumentos Musicais



servos



Interações Virtuais

**LEDS
RGB**

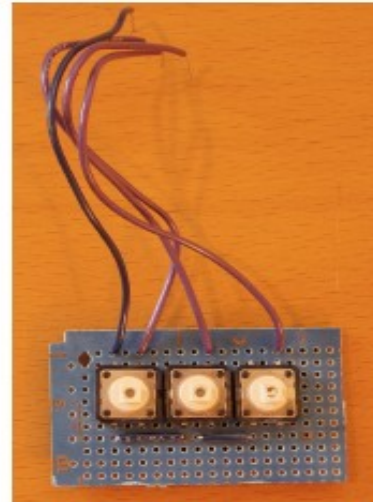
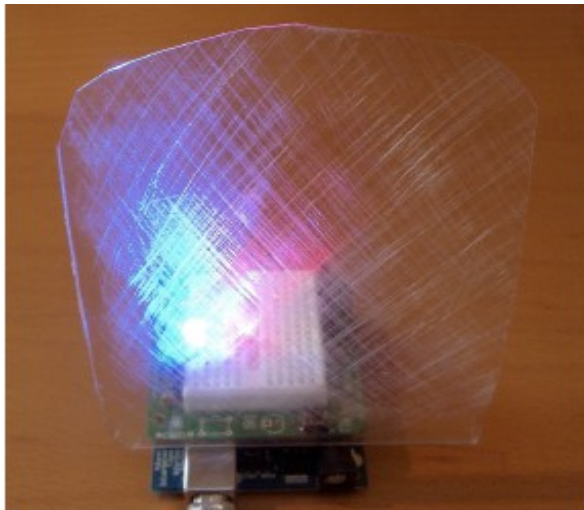

**Botões de
Comando**



Malmo University



Referencias

- www.arduino.cc
 - Download placas e software. Referencia da linguagem, Exemplos, Forum.
- www.blogdoje.com.br
- www.arduinoBr.com.br
- www.tato.ind.br
- www.sparkfun.com
- Livro “Physical Computing” , Tom Igoe

- 
- Duvidas
 - Informações
 - Questões
 - **Workshop em Junho 2008**

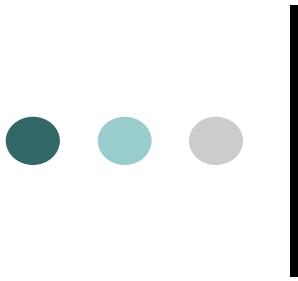

Muito
Obrigado !!!

jeronimo@blogdoje.com.br

www.blogdoje.com.br